

STANDARD TYPE-F Multiple Input Shaft

High Load Thrust & Torque Horizontal Input

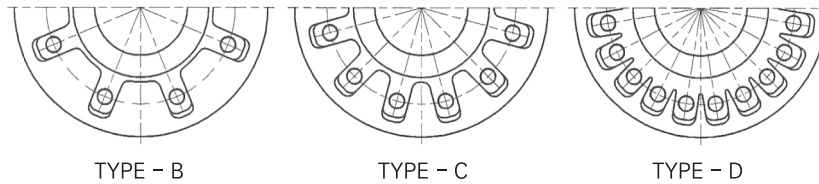
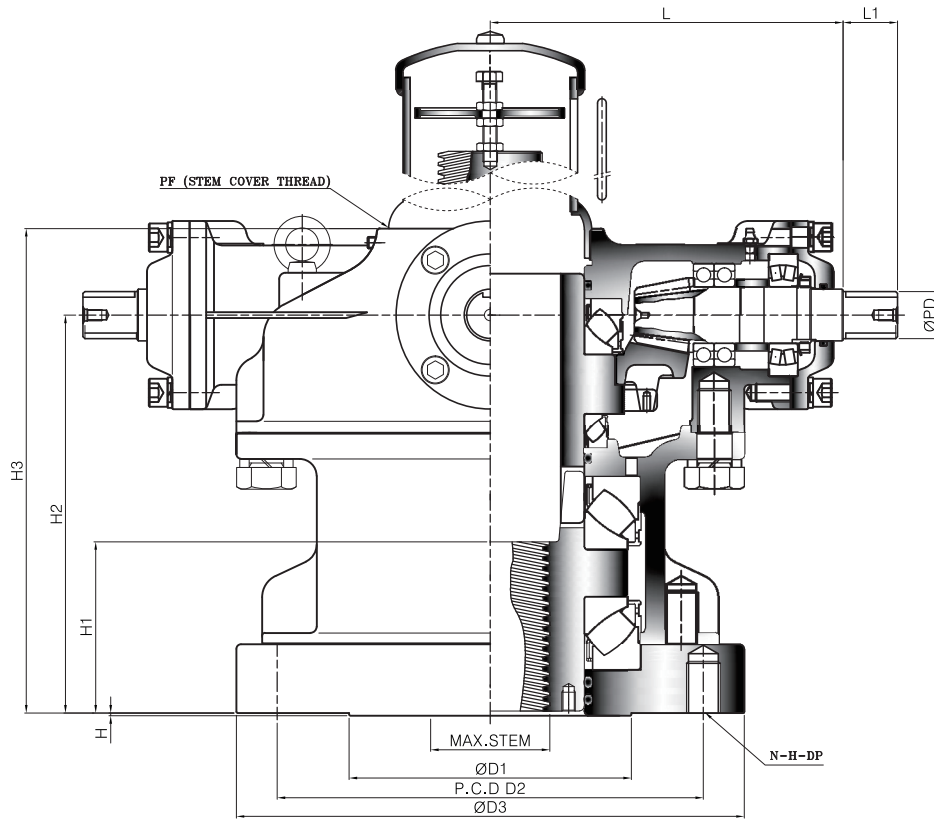

Dimension

UNIT : mm

DIM MODEL	BASE PART							EXTERNAL PART					INPUT SHAFT PART			HAND WHEEL	STEM COVER		
	TYPE	FLANGE	ØD1	P.C.D		ØD3	H	H1	H2	H3	L	L1	ØPD	KEY					
				ØD2	N-H-DP														
SB-V2HW	B	F-25	200	254	8-M16-24	300	3	99	229	273.5	188	34	32	10X8	630	PF3-1/2"			
SB-V3HW		F-30	230	298	8-M20-30	350		118	263	310.5	208				710	PF4"			
SB-V35HW		F-35	260	356	8-M30-45	415		143	316	373	266				800	PF5"			
SB-V4HW		F-40	300	406	8-M36-55	475		155	342	401	291				44	38	12X8	900	PF6"
SB-V5HW		F-40	300	406	8-M36-55	475		172	376	444	313				900	PF6"			
SB-V55HW	C	F-48	370	483	12-M36-55	560	5	186	410	479	333	44	38	12X8	900	PF6"			
SB-V6HW		F-48	370	483	12-M36-55	560		197	429	511	381				58	50	16X10	1000	PF8"
SB-V7HW		F-48	370	483	12-M36-55	560		217	475	562	409				1000	PF8"			
SB-V75HW	D	F-60	470	603	20-M36-55	700	5	229	505	597	441	58	50	16X10	1000	PF10"			
SB-V8HW		F-60	470	603	20-M36-55	700		242	540	635	472								
SB-V85HW		F-60	470	603	20-M36-55	700		269	612	706	525								
SB-V9HW		F-80	650	800	20-M42-63	900		281	636	739	591						PF12"		
SB-V10HW		F-80	650	800	20-M42-63	900		305	701	816	664								

Spiral Bevel Gear Actuators

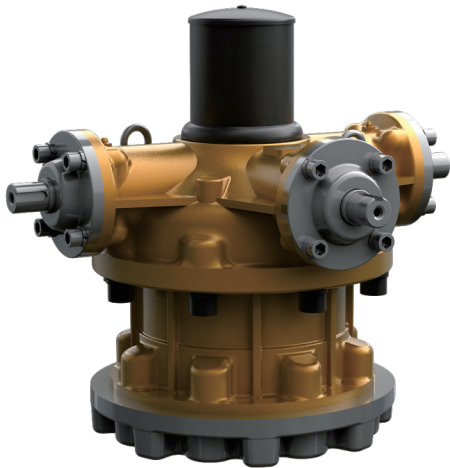

Disassembly flow chart of thrust bush for processing of stem thread

1. Remove base plate socket head cap screws and base plate.
2. Remove Gasket
3. Use eye-bolts from housing and thread into tapped holes on end of the drive bushing.
4. Lift drive bushing with lower roller bearing.
5. Remove roller bearing from drive bushing.
6. Thread bushing as required.
7. Add grease as necessary.
8. Re-assembly in reverse order.

❖ Feature

- This series suitable for extreme high thrust loads for use with Gate & Glove type valves. Also sluice gates and any other type requiring linear motion for high load thrust and torque applications.
- Bottom entry type stem nut. High tensile aluminum bronze material providing corrosion and abrasion resistance.
- Castings are Ductile Iron, class 65-45-12 providing high strength and impact resistance.
- Heavy duty roller bearings supporting both radial & axial thrust loads.
- Gears are Machine cut, heat treated and ground for optimum operation Units are completely O-Ring Sealed suitable for temporary submergence to meet Ip67 class.
- Many options, such as hand wheels, chain wheels, stem covers, position dial indicators are available.

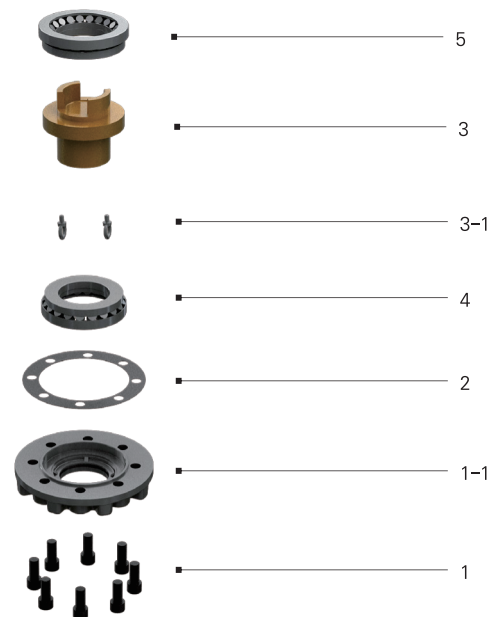

❖ Selection Chart for Manual Operation

MODEL	SIZE GEAR RATIO	MAX. STEM ACCEPTANCE		MOUNTING OPTION & STANDARD	MAX. THRUST CAPACITY		MAX. TORQUE CAPACITY		WEIGHT
		TW	KEY		KN	lbf	N-m	Ft . lbf	Kg
SB-V2HW	4 : 1	65	55 (16X10)	(F-20), F-25	1080	242800	2900	2139	65
SB-V3HW	5 : 1	80	70 (20X12)	F-25, F-30	1710	384400	4500	3319	96
SB-V35HW	5.5 : 1	95	85 (22X14)	F-25, F-30, F-35	2450	550800	7000	5163	162
SB-V4HW	6 : 1	110	95 (25X14)		2900	651900	9800	7228	207
SB-V5HW	6.56 : 1	130	115 (32X18)	F-30, F-35, F-40	3500	786800	15000	11063	273
SB-V55HW	7 : 1	140	120 (32X18)	F-35, F-40, F-48	4200	944197	19000	14014	399
SB-V6HW	7 : 1	150	130 (36X20)	F-35, F-40, F-48	4700	1056600	23000	16964	535
SB-V7HW	7.56 : 1	170	150 (40X22)	F-48	5200	1169000	37000	27290	607
SB-V75HW	8 : 1	190	170 (40X22)	F-48, F-60	6800	1528701	46000	33928	878
SB-V8HW	8 : 1	215	185 (45X25)	F-48, F-60	7650	1719800	58000	42778	970
SB-V85HW	8 : 1	225	195 (45X25)	F-48, F-60	9100	2045760	74000	54579	1238
SB-V9HW	8 : 1	240	215 (50X28)	F-60, F-80	9400	2113200	104000	76706	1819
SB-V10HW	8 : 1	270	240 (56X32)	F-60, F-80	11500	2585300	142000	104734	2002

Size and component specification in this catalogue are subject to change without prior notice for quality improvement.